

CAMPING IN YOUR HOUSE

Jim Buck (928-2177) buckdj@olypen.com

Website: <http://jeppgroup.org/> Presentations: buckdj@olypen.com

The community of Joyce expects to be isolated after a catastrophic earthquake. Landslides to the south and west and bridge failures over the Elwha River will cut off the community from outside assistance for several weeks. Mutual assistance from the rest of the United States may take a month to get here.

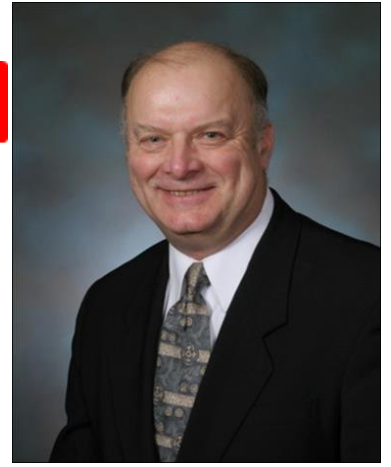

A volunteer group called Joyce Emergency Planning and Preparation (JEPP) is cooperating with Clallam County Emergency Management and Fire District #4 to prepare a response plan for this disaster. The plan includes rescue, emergency response, emergency shelter arrangements, hasty transportation repairs, law enforcement, emergency communications and food/water distribution.

Assess your shelter



If your house looks like this you might want to salvage materials and build a shelter... or use a camper to shelter in place.

You need to assess your house to see if it is safe to stay in. There will be aftershocks that could cause further damage and unsafe conditions. If the house looks like the one on the left you'd better find another place. At best, you might be able to salvage materials from this house to construct an emergency

shelter and recover essential survival supplies. You might still be able to shelter on the property in a camper or out building.



If your house looks like this you might want to use it to shelter in place.

If your house looks like the one in the second picture, you might consider cleaning up the rooms, putting plastic on the windows, fixing the chimney and shoring up the structure so you can stay in it until help from the rest of the country arrives.

Prep Your Shelter



Minute Man Anchors, inc.

Galvanized G-115 Strapping for Side Mounted Tank Anchoring System



- 2 pieces of Galvanized G-115 Strapping
- 2 pieces of Vinyl Strap Sheathing
- 4 Auger Anchors or optional Concrete Anchors
- 4 Strap Bolts & Nuts

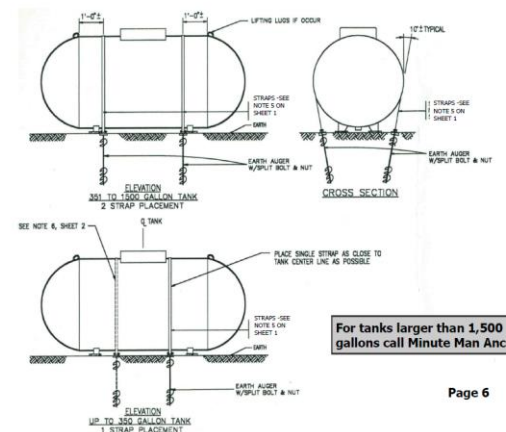

Repair your shelter



You will need to make sure your house is safe from aftershocks and other hazards before you can move back in. Unsafe conditions include partially collapsed masonry chimneys, façades and walls. Also look for items that can fall on you such as cabinets, pictures, ceiling panels, lighting fixtures and game heads. Repairs can be done in stages. Pick one room that will provide safe shelter from wind, rain and inclement weather. Remove the hazards. Perform any needed shoring and carpentry activities. If necessary, place tarps over the roof to stop leaks and cover the windows with transparent plastic. Once you have a secure place you can branch to other parts of the home to improve your position. There will be little else to do during the first few days after the quake. Repairs will have to be examined after each aftershock to make sure weakened and damaged walls, ceilings and roofs are still safe.

Items handy for repair



Handy items to have in your emergency stash include plumbers tape. This stuff is very effective for making temporary repairs to walls and ceilings.

Tarps and plastic are great for fixing roofs, patching windows and building emergency structures. Timberlock screws are magic for joining broken structural members or building strong frames. You will need a charged electric screw driver to use these or a good socket wrench.

Plastic snap ties with duct tape are legendary in emergencies for everything from fixing airplane wings to bandages.

Predrilled metal channels make excellent structural clips when used with nails or sheet rock screws.

Number 9 tie wire allows you to tie almost anything together quickly. High strength fishing line, baling twine and string are all cheap alternatives to high priced rope.

Clean up your shelter



As soon as you are finished repairing your “house”, you need to thoroughly clean and disinfect it. We all have plenty of forgotten brooms, soap, gloves and bags stashed in a closet or the garage. Disinfection is particularly important.

Routine medical care for cuts, colds, flu and intestinal problems may not be available after the quake. Medical services might have to be reserved for more serious conditions. You can eliminate these problems by keeping the house clean. Shelter procedures call for washing down walls, floors, furniture and equipment daily. You should do this too.

Be sure to clean up all the sawdust, glass, insulation and any other trash in your “house.” You must eliminate all items that could injure you or make you sick. Dispose of your trash/rubble in heavy duty plastic trash bags and keep them in a location where they will be intact when trash collection resumes.

Be sure to make arrangements to keep your outdoor footwear out of the house so you do not track contaminated material into your shelter.

Build a tent in your shelter



Camping in your house is not a new concept. Humanity has camped inside structures for thousands of years. From lowly serfs in huts to royalty in magnificent fairytale castles, tents inside a room have been the preferred way to pass a cold winter night.

This is Crazy King Ludwig’s tent/bed in the Neuschwanstein Castle in Germany. The castle was the inspiration for the Disneyland Castle. Even with steam heat it was impossible to keep warm. So Crazy Ludwig hired a team of carpenters to build his tent. It took 4 years and helped bankrupt the country. When it was time to go to bed, he pulled the curtains and slept in a warm micro-climate. Note his indoor commode disguised as a foot stool to the right of the bed. This was a substitute for indoor plumbing. It is a commode. Keeps you somewhat warmer than having to go outside and (I digress).

More affordable tents



When I was a kid, our family experienced a number of blizzards, hurricanes and emergencies where we lost electricity. We reduced our house footprint to our dining room and kitchen. Sheets or curtains covered doorways to isolate our “shelter” from the rest of the house. This minimized the area we needed to heat. Our power outages were never more than 2 days long so we never had to pitch a tent in the house. If we were facing an indefinite outage we might have put one up. These homeowners picked a room under a good roof with a dry floor and a southern exposure so the sun will keep the room and tent warm during the day. An enterprising person might place a mattress or some other cover between the floor and tent for insulation (only works if it is dry and will stay dry). Note the single person tent on the couch. This is your sleeping micro-climate. This central location allows you to rest comfortably while you clean up the other rooms in your home. It is essential that you keep this place as clean as possible. Footgear you wear outside may be contaminated with sewage. Remove that footgear before you enter the house and keep it where it can not contaminate your safe space..

Warming your bed



We are all familiar with the poem “The Night Before Christmas.” Several verses chronicle the lost art of sleeping in an unheated room, “And mamma in her 'kerchief, and I in my cap, had just settled our brains for a long winter's nap.” Night caps and night gowns are things of the past for most of us but I’ve used them on hunting trips in the Arctic. A linen sleeping bag liner can substitute for a night gown. The liner and the hat allow a sleeper to be comfortable in temperatures 10 to 15 degrees lower than the lowest temperature rating for the sleeping bag. Most human heat loss comes from the head, hands and feet. A cap, gloves and socks limit the heat loss and scarf around the middle is also helpful.

In past centuries, mankind struggled to find ways avoid climbing into an ice cold bed. Solutions include hot water bottles and bed warmers containing hot coals from the fire. However, we should not forget the doggies and the kitties. Our house hosts a number of doggies and kitties and we value their constant 102.5 degrees bed warming effect. We conclude that we will never freeze as long as we have cat food and dog food to fuel the cat and dog food powered bed warmers.

Water Purification

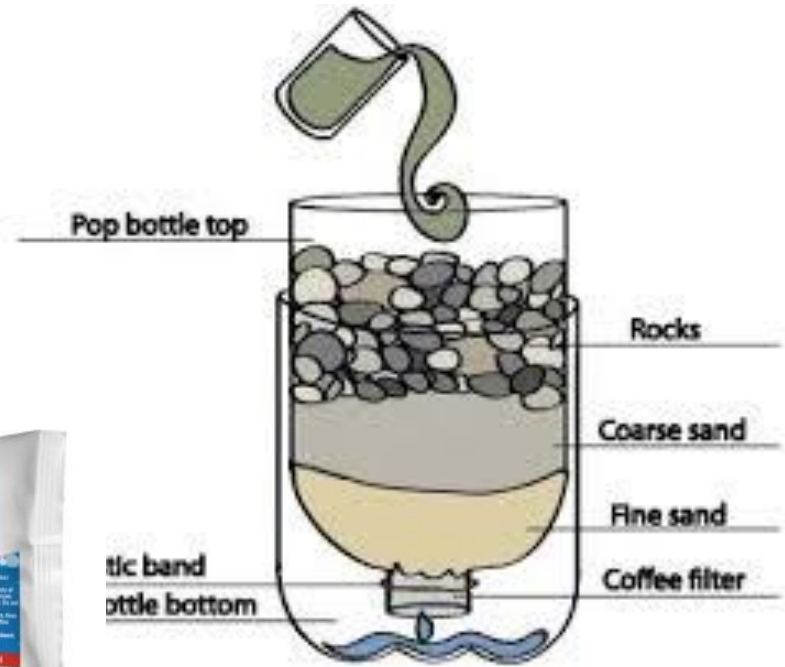

The American Red Cross says each of us needs about 1 gallon of water a day to survive. FEMA predicts that most water systems in western Washington will be put out of action by a Cascadia earthquake. About 1/3 of the region's water treatment capacity may be restored when the power comes back on. That may take up to a year. The rest will have to be rebuilt.

History is filled with stories of epidemics which occur after natural disasters because the water supply is tainted. Experience from the Christchurch New Zealand quakes shows damage to sewer lines contaminated the streets and streams throughout the town. There will be few sources of uncontaminated water so you need to plan to purify your own drinking water.

You can store water but it has to be rotated periodically and takes a lot of space.

It will be worth your time to check online and find the solution that works best for your family. The community of Joyce built a small portable manually operated water treatment plant that chlorinates and filters 6 gallons per minute for its emergency shelter..

Food Supplies



Government contingency plans for the earthquake tell us we must be prepared to be on our own for 30 days. The Red Cross recommends each person consume a minimum of 2,200 calories per day. You will want about 1 pound of food per meal or 90 pounds of food per person for the month. Here are some samples of prices for various foods.

When times are tough, good food has always been used as a morale booster. This event will be the toughest time most of us will ever deal with so make sure your stash has comfort foods. Popcorn, candy, chocolate are treats that lighten the mood and lift the spirit. Spirits are good to have on hand for the adults too. Strictly for medicinal purposes of course.

Cooking



If you are camping in your house you will probably want to cook and eat inside. It's just more comfortable and cleaner too. You will need some kind of camp stove to do this. You already have all the utensils you need in the kitchen. Get a stove with enough fuel to fit your needs. Pick a fuel with a long shelf life. Set it up on a secure table or counter. Be aware of the fire hazard it may pose to cabinets, curtains and furniture during aftershocks or normal operation. Cooking indoors on a cook stove is not much different than using a kitchen stove.

If you find a need to cook outdoors for a long period, plan on building an improved cooking area. Oven/refrigerator metal grills can be used over a fire. Dutch ovens will come in handy and are worth the time and effort to learn about. Cooking outdoors over a fire takes a little getting used to but goes on all over the world every day. You can do it.

UNDER NO CIRCUMSTANCES BURN CHARCOAL INSIDE OF A STRUCTURE OF ANY KIND (including tents). CHARCOAL RELEASES LARGE AMOUNTS OF CARBON MONOXIDE GAS. IT IS ODORLESS AND COLORLESS. IT WILL RUIN YOUR EARTHQUAKE CAMPING EXPERIENCE AND MAY KILL YOU.

The Bathroom



Above are samples of toilets without plumbing. These have the ability to gather waste in comfort and privacy without having to run out to an outhouse in the rain or snow.

The Joyce shelter plans on removing the toilets in the men's and ladies' rooms and replacing them with hospital commodes. This gives people the ability to continue toileting as usual instead of requiring trips to latrines or outhouses. The waste will be collected in 5 gallon buckets and disposed of in nearby septic tanks. The septage will filter out to the drain fields as it normally would. Septic systems with lift pumps may have to be pumped several times a day using generator power. Be sure to add raw water to the septic tank to make up for the lack of toilet flushing. It is essential that nothing go in the septic but waste and toilet paper to avoid plugging the drain field.

Human Waste Disposal



You need to think about what you are going to do with your waste after the earthquake. Remember, Christchurch, New Zealand and Haiti experienced extreme sanitation problems after their earthquakes. It led to life threatening disease outbreaks. We need to limit the amount of sewage flowing through our communities as much as possible. There is no getting around the fact that each of us passes about 1/2 gallon of urine and 1 pound of feces a day. We are so used to flushing a toilet that we don't think about waste disposal.

Our waste disposal system depends on flush water. No flush water, no working sewer system. Broken sewer pipes complicate your problem. If you have a septic system, you can collect your waste, open the top of the septic tank and pour the waste into the tank.

If you don't have a septic system there is a different way to deal with the waste. This involves dry composting. Urine and feces are collected in separate buckets. This limits unpleasant odors. The feces is placed in a heavy duty trash bag and mixed with an equal part of sawdust, peat moss or wood chips. Store the bag in a sheltered place until it can be collected. Urine can be disposed of in a designated place in your garden or neighborhood.

Light, Heat and Fuel



A group of Joyce (JEPP) volunteers spent hours discussing ways to provide light, heat and fuel for the Joyce emergency shelter. FEMA advised that we can expect to be without electricity from the grid for up to a year. They also advised that we could expect no fuel resupply for 1 month. We concluded that the least cost and most efficient solution was to rely on proven low tech equipment like candles, kerosene lanterns and heaters. Gasoline, diesel and kerosene will be available when the military arrives. Low tech avoids costly investments in lighting systems that rely on batteries, solar or fuels that cannot be stored for long periods. The kerosene lantern on the left uses 1/2 ounce of kerosene per hour and does not have a mantle that will break during an aftershock. It also provides a small amount of heat. Be sure to protect it from after shocks.

Water Trailers



Anchor Propane Tanks



Minute Man Anchors, Inc.

Galvanized G-115 Strapping for Side Mounted Tank Anchoring System



- 2 pieces of Galvanized G-115 Strapping
- 2 pieces of Vinyl Strap Sheathing
- 4 Auger Anchors or optional Concrete Anchors
- 4 Strap Bolts & Nuts

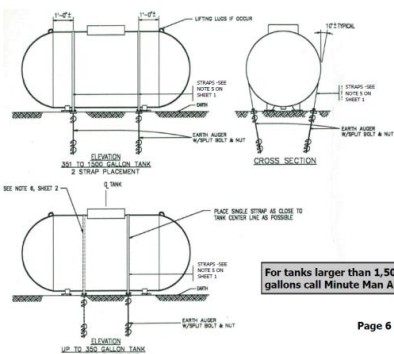

For tanks larger than 1,500 gallons call Minute Man Anchors



Turn Off the Gas

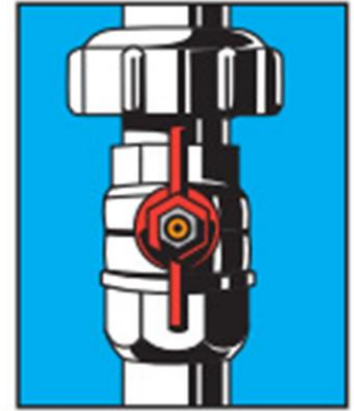
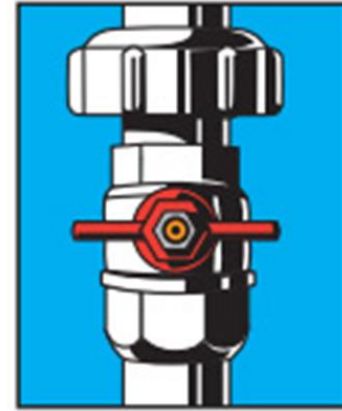
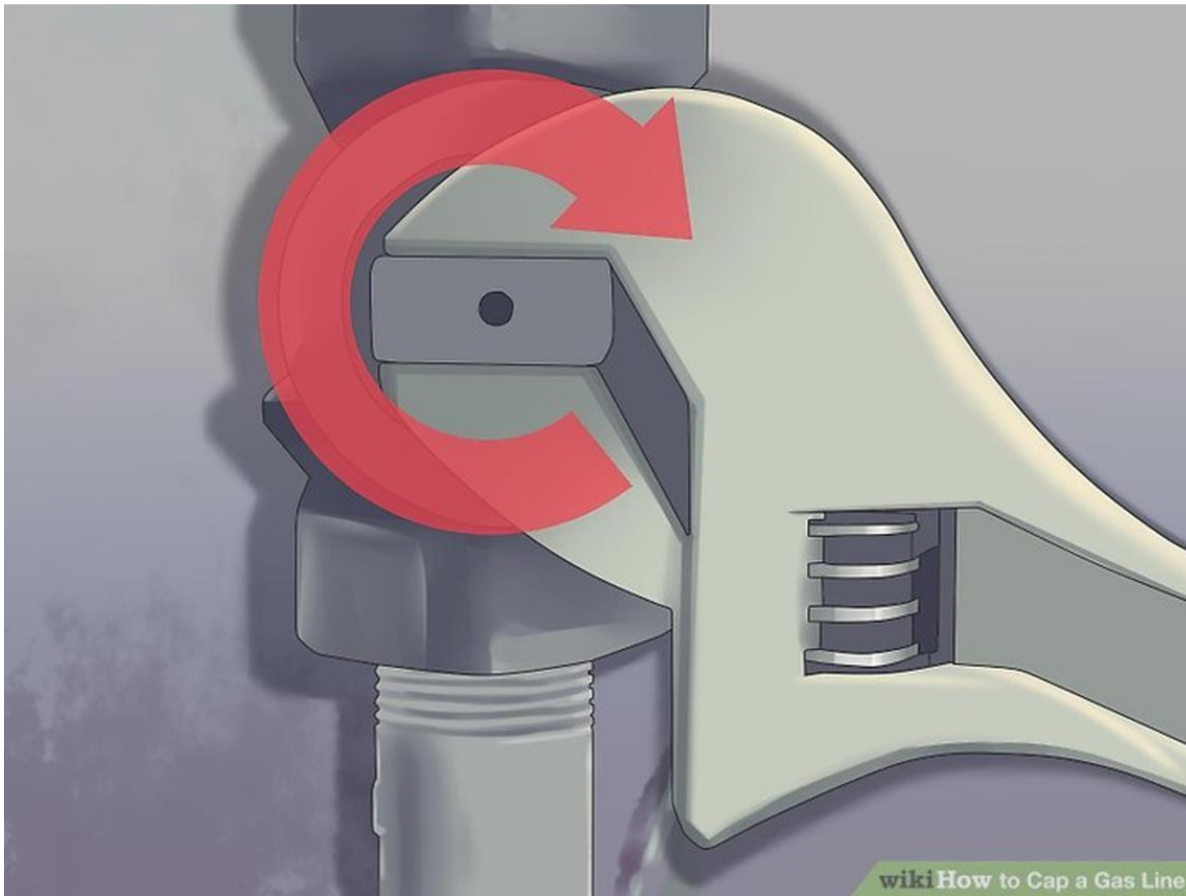

Area Command 3 – Joyce Plan

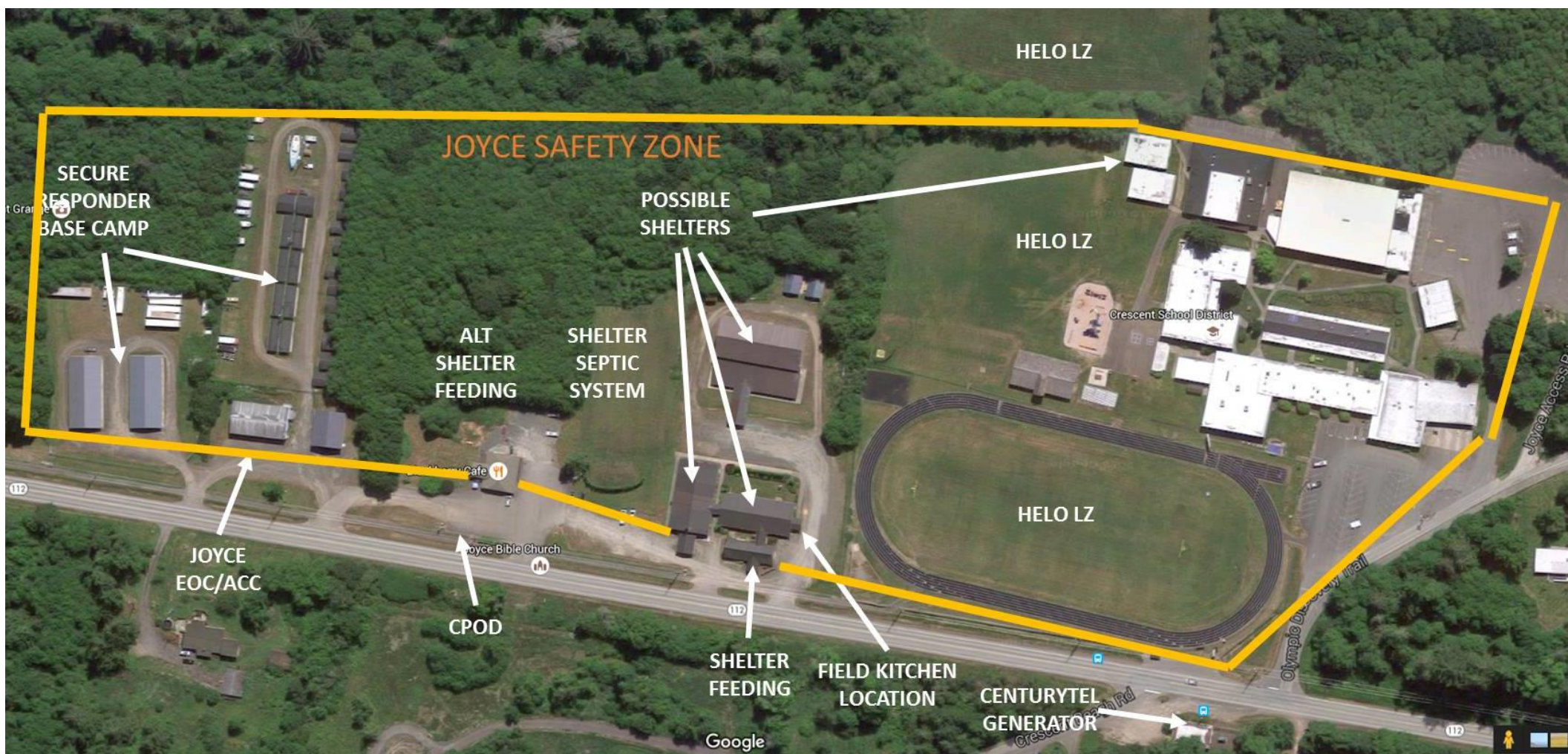

Joyce Emergency Cache



10K Generator



Field Kitchen

